



BROMPTON PENTA CLIP

The Pentaclip is designed for rail saddles with a rail spacing of 43 mm (centre to centre) and a rail diameter of 7 mm, though it will cope with a reasonable variation in these. If the saddle's rails are closer together the pentaclip may feel stiff when the angle is adjusted.

Fitting pentaclip to a saddle

Unscrew the bolt from the threaded part LPT and slide bolt, washer and part LPU out together (Fig SP07). While doing this, hold the pentaclip by squeezing the two parts RP together: this stops the pentaclip clutch-plate assembly coming apart. Still holding the clip in this way, slide it between the rails of the saddle.

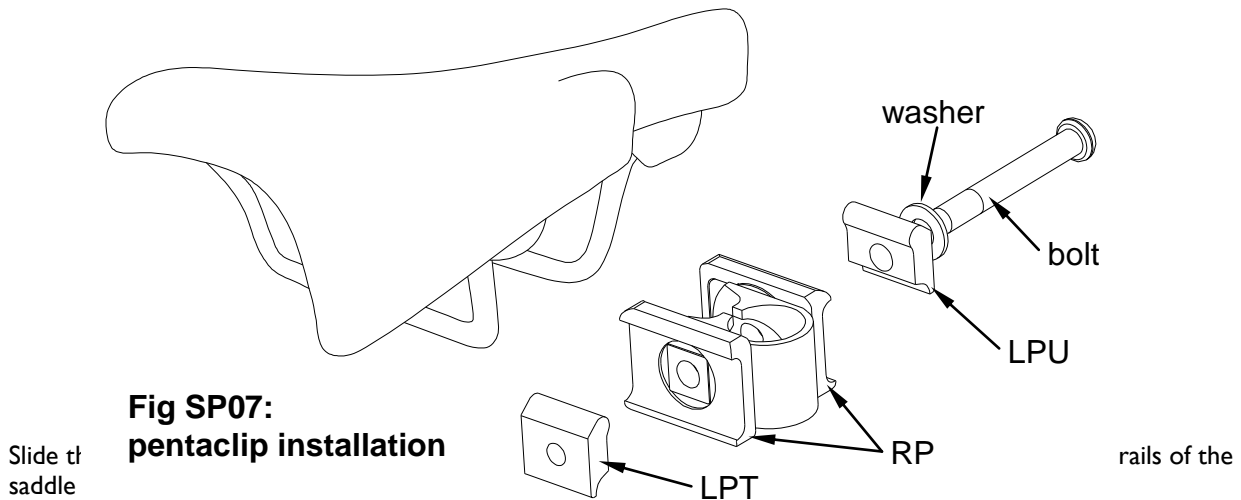

The concave groove in parts LPU and LPT should engage with the saddle rail (Fig SP10).

Check there is grease on the bolt thread and screw the bolt into threaded part LPT so the parts are held in place but are still a little loose.

Fitting saddle and pentaclip to bike

Slide the pentaclip onto the seat post, positioning about halfway up the small diameter part of the seat-post. This will ensure enough clearance from the saddle to the seat post for optimum comfort, and enough clearance from the Pentaclip to the frame to avoid accidentally damaging the paint.

Set seat to the desired angle and fore-aft position and tighten bolt to 15Nm. Do not over tighten the bolt as this can damage the thread.

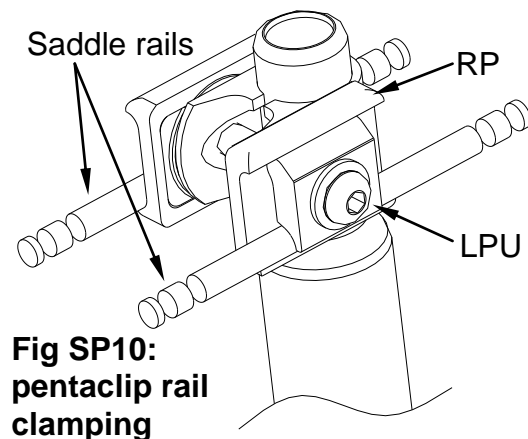

Adjusting seat angle

To adjust the seat angle undo the Allen bolt such that it is loose enough to be rattled (even a small amount of force on the bolt will clamp the Pentaclip tight). Move the saddle to the desired angle and retighten to 15Nm.

Changing saddle height

The pentaclip allows two saddle heights. With the upper position you gain about 20mm but the saddle projects that much further from the folded package. The clamp band can also be rotated around the bolt to give a forward or

rearwards position. The forward position with the saddle pushed forward on its rails gives the smallest folded package.

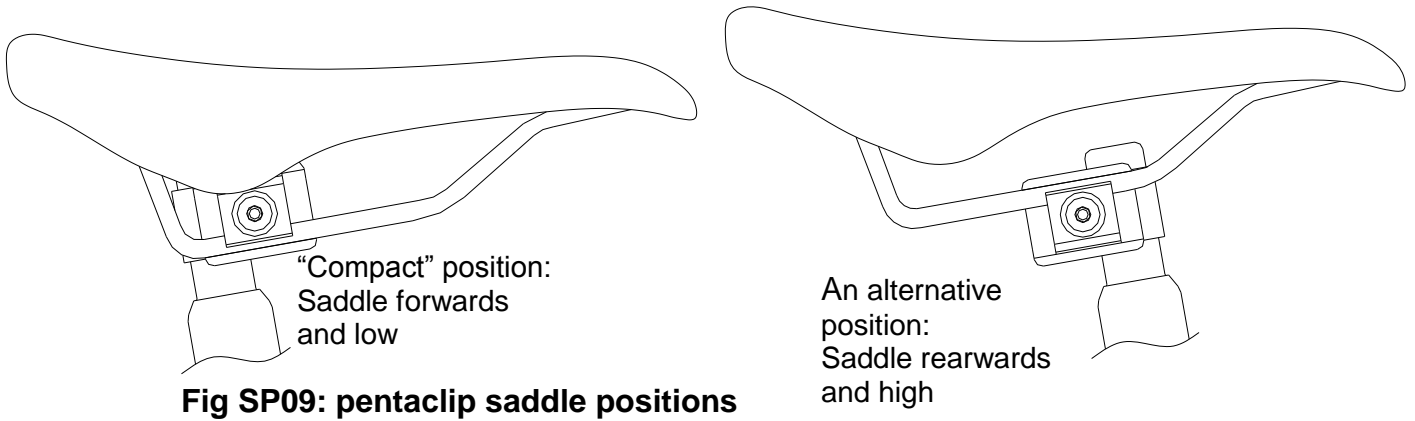

Re-assembly if clutch plates are released

If plates *do* come apart the pentaclip can be reassembled with the clutch-plates fitted into the rail-plates (RP) in the order shown below. Plates MCP should be fitted with the formed 'ears' offset towards the outside of the bike (in order to engage fully with the rail-plates RP). The plates FCP may be a tight fit on the square splines A.

