



## FOLDING PEDAL.

All Brompton folding pedals fitted or sold prior to January 2012 utilise either a 24mm flat hexagon steel bolt or a Titanium bolt with a 10mm hexagon socket to attach the pedal.

From January 2012 an updated folding pedal was introduced along with a new forged steel bolt and Aluminium spacer. This bolt has both an 8mm hexagon socket in the head and a 6mm in the threaded end. This new bolt replaces the previous two on all bikes.

Nearly all Brompton folding pedals are fitted to the non-drive side crank which has a left hand thread. Right hand versions are also available.

All folding pedals, bolts and spacers are compatible in any combination as long as you have the correct thread direction for the crank.

The following fitting instructions apply to both models of folding pedal, either left or right hand. Only the required tightening tools vary.

**NOTE: In all cases the spacer (S) must be in place between the bearing and the crank. Without this spacer the pedal will contact the crank and hinder rotation causing irreparable damage.**

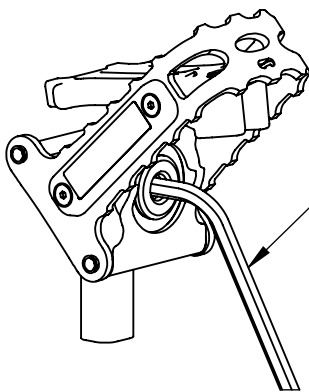

- 8mm Allen key for 2012 forged bolts or 6mm Allen key in threaded end.
- 24mm socket tool for early steel bolts
- 10mm Allen key for early Titanium bolts

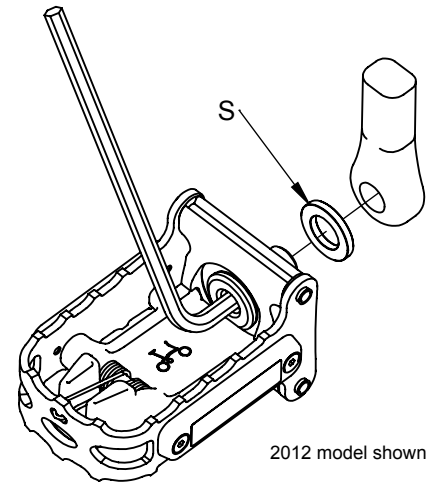

2012 model shown

- Insert the bolt into the bearing from the inside of the pedal. You will have to depress the plastic latch a little for access.
- Place the spacer (S) on to the protruding bolt threads.
- Use a finger or an appropriate Allen key to hold the bolt steady from the inside and offer the pedal up to the crank.
- Ensure the spacer is present and start to screw in the bolt. For left hand thread turn bolt anti-clockwise. Once started you can partially fold the pedal for greater access to the bolt.
- All bolt types must be tightened with **30N m** of torque with a correctly fitting tool. Ideally a torque wrench should be used.

**NOTE: 24mm flat hexagon bolts require a 24mm socket tool. It is impossible to achieve 30N m without the correct tool.**



## FOLDING PEDAL.

All Brompton folding pedals fitted or sold prior to January 2012 utilise either a 24mm flat hexagon steel bolt or a Titanium bolt with a 10mm hexagon socket to attach the pedal.

From January 2012 an updated folding pedal was introduced along with a new forged steel bolt and Aluminium spacer. This bolt has both an 8mm hexagon socket in the head and a 6mm in the threaded end. This new bolt replaces the previous two on all bikes.

Nearly all Brompton folding pedals are fitted to the non-drive side crank which has a left hand thread. Right hand versions are also available.

All folding pedals, bolts and spacers are compatible in any combination as long as you have the correct thread direction for the crank.

The following fitting instructions apply to both models of folding pedal, either left or right hand. Only the required tightening tools vary.

**NOTE: In all cases the spacer (S) must be in place between the bearing and the crank. Without this spacer the pedal will contact the crank and hinder rotation causing irreparable damage.**

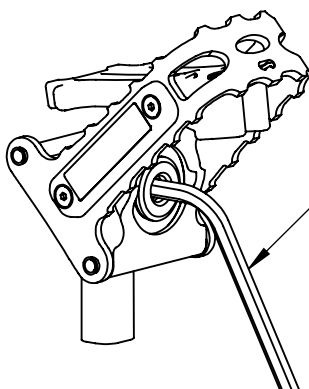

- 8mm Allen key for 2012 forged bolts or 6mm Allen key in threaded end.
- 24mm socket tool for early steel bolts
- 10mm Allen key for early Titanium bolts

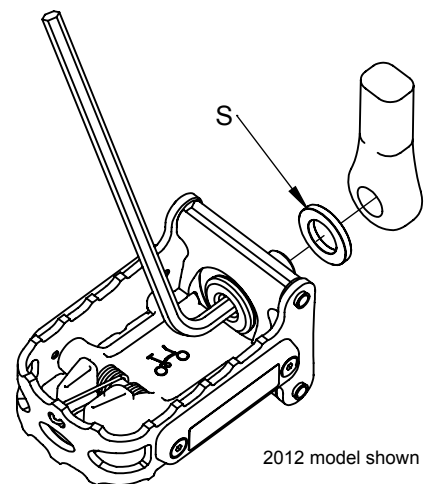

2012 model shown

- Insert the bolt into the bearing from the inside of the pedal. You will have to depress the plastic latch a little for access.
- Place the spacer (S) on to the protruding bolt threads.
- Use a finger or an appropriate Allen key to hold the bolt steady from the inside and offer the pedal up to the crank.
- Ensure the spacer is present and start to screw in the bolt. For left hand thread turn bolt anti-clockwise. Once started you can partially fold the pedal for greater access to the bolt.
- All bolt types must be tightened with **30N m** of torque with a correctly fitting tool. Ideally a torque wrench should be used.

**NOTE: 24mm flat hexagon bolts require a 24mm socket tool. It is impossible to achieve 30N m without the correct tool.**

## Fold/Unfold Method

**To fold the pedal up:** Position the cranks with the folding pedal uppermost. Depress latch at point (A) or push latch up in direction (B) and pivot the cage up over the end of the crank arm.

The pedal will naturally reside vertical and the latch will rest on the small ledge at the back of the crank to prevent the pedal from contacting the frame.

Drive side crank arms and some older bikes will not have this ledge. Only more recent Brompton cranks have this feature.

**To fold the pedal down:** Swing the cage down until the latch engages with a sharp click sound. The pedal is self locking and always safe to use on either platform.

It is possible to preserve the feel of the pedal and experience maximum stiffness underfoot by always using it with point (A) uppermost. This is by no means essential and the pedal is equally safe to use on either platform.

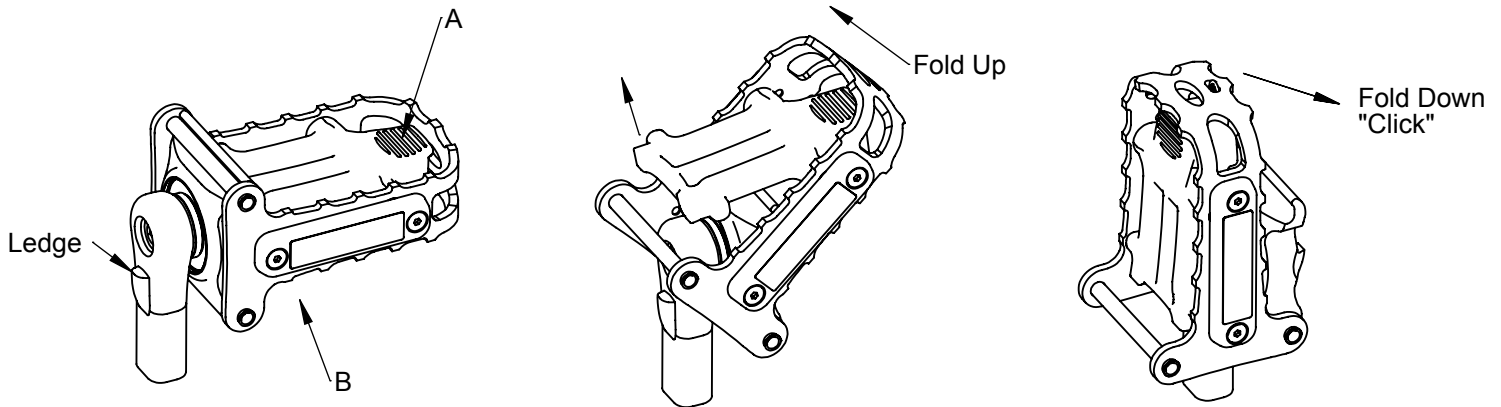

Replacement reflectors, complete pedal kits and individual bolts, both left and right hand, are also available.

## Fold/Unfold Method

**To fold the pedal up:** Position the cranks with the folding pedal uppermost. Depress latch at point (A) or push latch up in direction (B) and pivot the cage up over the end of the crank arm.

The pedal will naturally reside vertical and the latch will rest on the small ledge at the back of the crank to prevent the pedal from contacting the frame.

Drive side crank arms and some older bikes will not have this ledge. Only more recent Brompton cranks have this feature.

**To fold the pedal down:** Swing the cage down until the latch engages with a sharp click sound. The pedal is self locking and always safe to use on either platform.

It is possible to preserve the feel of the pedal and experience maximum stiffness underfoot by always using it with point (A) uppermost. This is by no means essential and the pedal is equally safe to use on either platform.

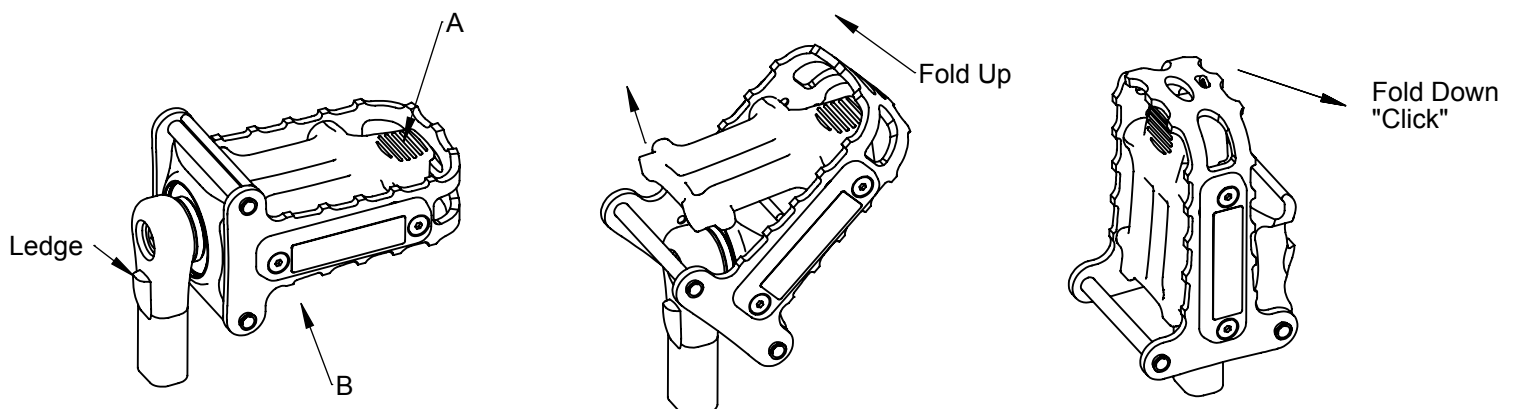

Replacement reflectors, complete pedal kits and individual bolts, both left and right hand, are also available.