

OPTIONEN / OPTIONS

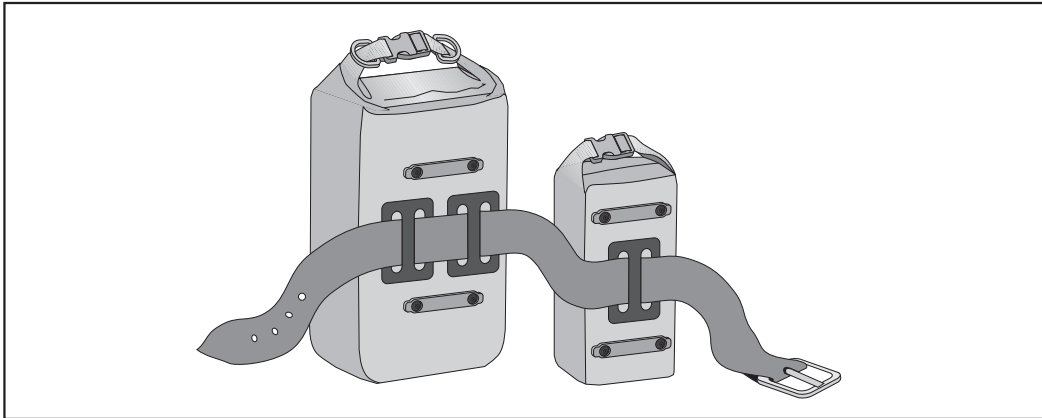

ACCESSORIES

= # / Art.-Nr. E 150

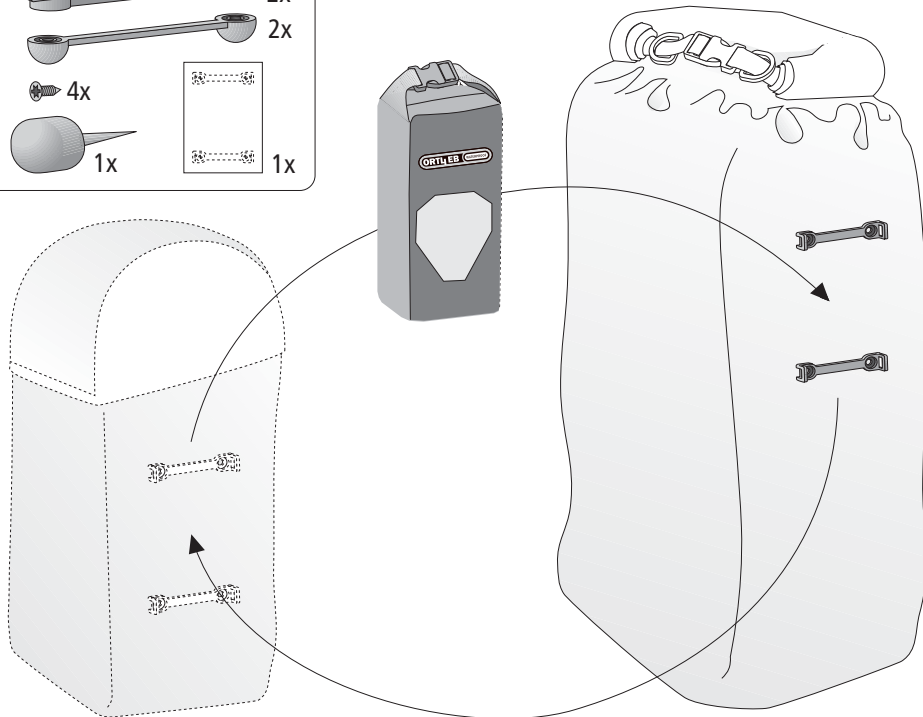
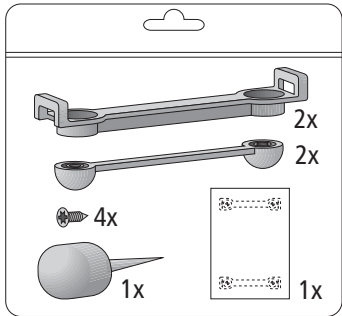

AUSSENTASCHE / OUTER POCKET

ORTLIEB WATERPROOF

- | | | | |
|-----------|---------------------------------|-----------|----------------------------------|
| D | MONTAGEANWEISUNG: | E | INSTRUCCIONES DE MONTAJE: |
| GB | ASSEMBLY INSTRUCTIONS: | S | MONTERINGSANVISNING: |
| F | INSTRUCTIONS DE MONTAGE: | N | MONTERINGSANVISNING: |
| I | ISTRUZIONI DI MONTAGGIO: | SF | ASENNUSOHJEET: |
| NL | MONTAGE HANDLEIDING: | PL | INSTRUKCJA MONTAZU: |
| DK | MONTERINGSVEJLEDNING: | J | 換気の良い所に保管してください。 |

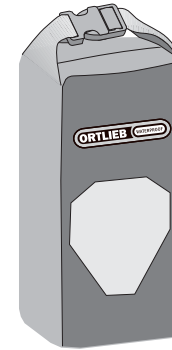

Size S; # F 91S

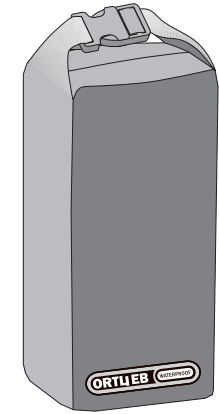

Size L; # F 91L

INHALT:
CONTENTS:
CONTENU:
CONTENUTO:
INHOLD:
INDHOLD:
CONTEENIDO:
INNEHÅLL:
INNHOLD:
SISÄLLYS:
ZAWARTOSC:
内容物

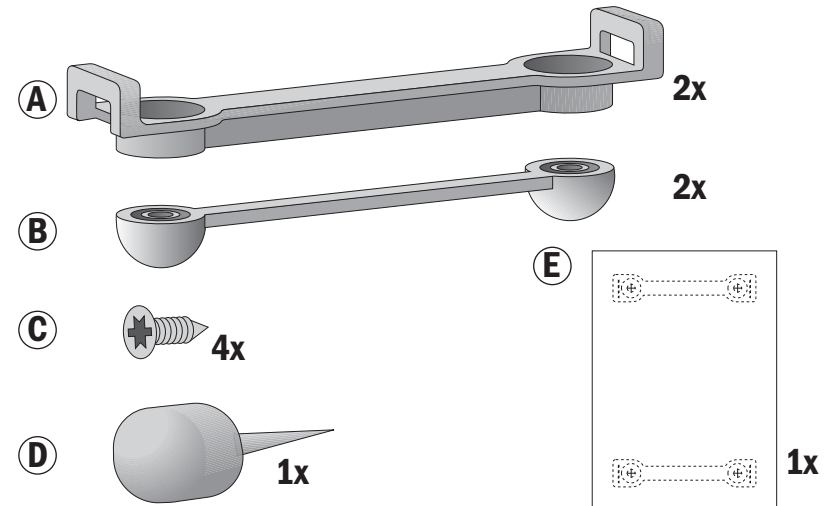

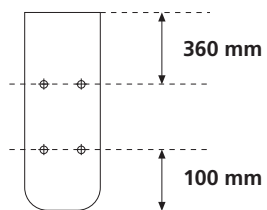
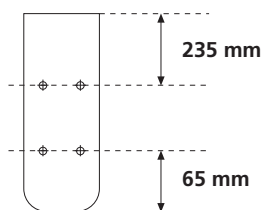
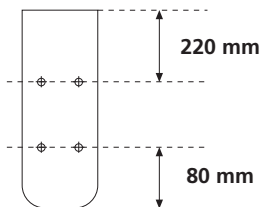
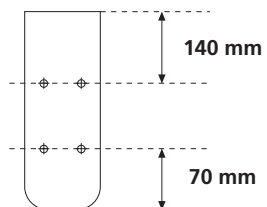
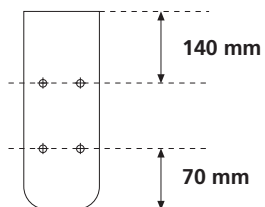
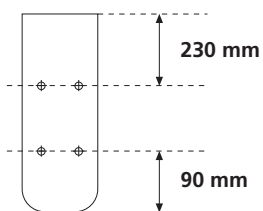
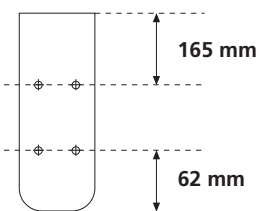
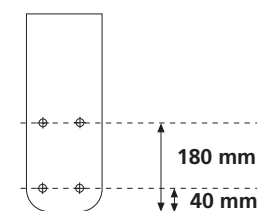
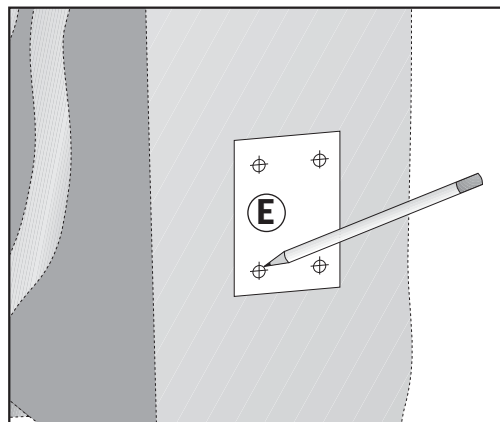
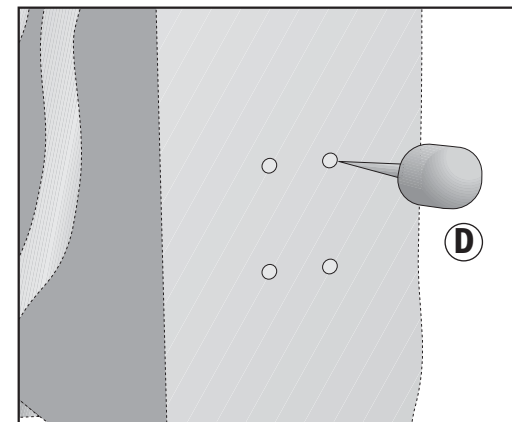
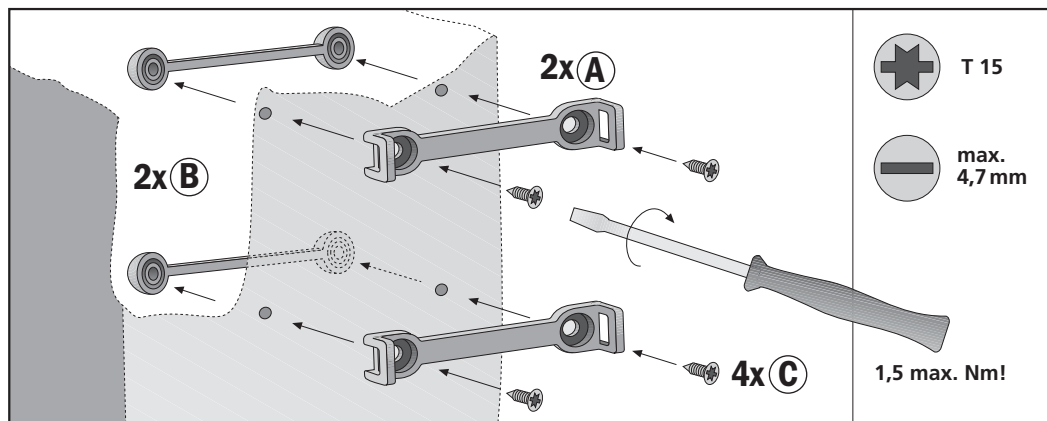
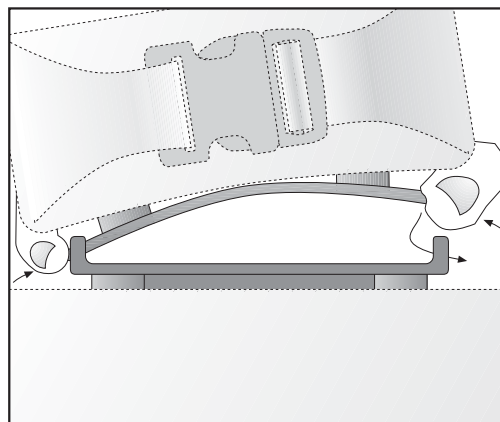
ASIZE **(S)** = ✓SIZE **(S)** / **(L)** = ✓**B**SIZE **(S)** (1,8 l)Ortlieb
Back-RollerOrtlieb
Bike-PackerOrtlieb
Bike-ShopperOrtlieb
Bike-TourerOrtlieb
Velo-ShopperOrtlieb
Front-RollerOrtlieb
Sport-PackerOrtlieb
Downtown**1****2****3****4****5**