



Feb-11 fcba ds

FRONT CARRIER BLOCK.

- Check that you have all the parts shown in the diagram below.
- If fitting for the first time, remove the two set screws in the brazed-on mounting block on the head tube: Older bikes - black nylon with slot, newer bikes - steel with 2.5mm hex drive.
- It is vital that you do not omit either of the serrated washers 'W' when fitting the retaining plate 'RP' and that the correct torque is used on the screws 'SHS'.
- The blue patches on the screws are there to lock them in place. Do not tamper with, remove or expose this patch to moisture as the locking action will be greatly reduced.

Fitting instructions

You need a 4mm Allen key and a Posidriv screw-driver: Assemble the retaining plate 'RP' and one of the M5 socket head screws 'SHS', together with its washer 'W' into the body of the carrier block 'FCB'. Address this to the head tube on the bicycle the correct way up as shown.

- Do up the first screw, but do not tighten.
- Insert and do up the second screw with washer 'W'.
- Finally **tighten both screws firmly** to a Torque of 4N m
- Feed the bottom end of the latch lever 'LL' through the hole in the base of the carrier block 'FCB' and then, holding the bottom of the latch lever, position the top of the latch lever inside the carrier block.
- Feed the self tapping screw 'ST' through the hole in the latch lever and secure **firmly** into the carrier block.

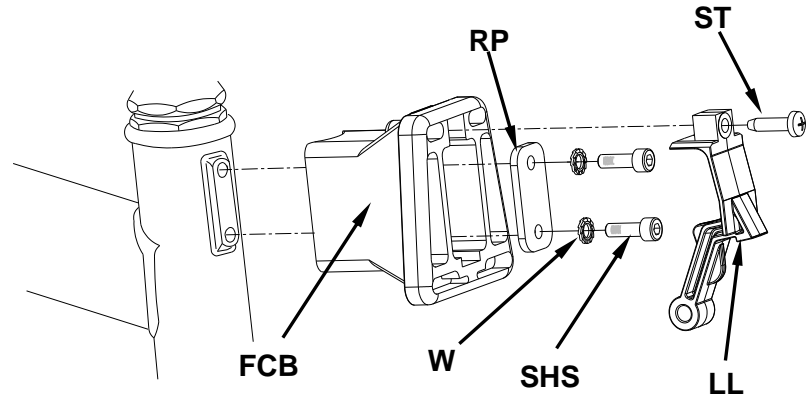

The screw 'ST' must be fully screwed home:

If the latch is not properly locked in place, it will be ineffective and luggage may fall off, which is dangerous.