



**HUB DYNAMO LIGHTING SYSTEMS, FITTING OF PARTS.**

**Read First**

This data sheet includes fitting instructions for all hub dynamo parts by covering procedures on fitting an entire hub dynamo set in order. It may well contain information which is not relevant to the individual parts you are fitting so please skip to the appropriate section listed on the right.

**Sections**

- 1) Fitting the Hub Dynamo Wheel
- 2) Fitting the Front Lamp Bracket
- 3) Fitting and connecting the Front Lamp
- 4) Routing and securing the Rear Loom
- 5) Fitting the Rear Lamp

**I. Fitting the hub dynamo wheel**

The fitting of the hub dynamo wheel is similar regardless of the hub type (Shimano F703 shown).

Insert the hub dynamo wheel into the fork dropouts with the contacts on the right hand side of the bike.

The contacts should be pointing forwards at 90 degrees to the dropouts (fig EL05).

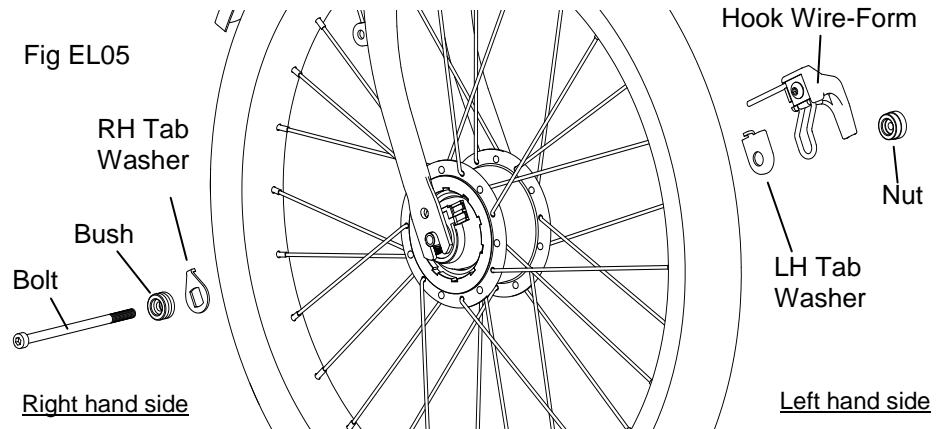

Replace with the same tab-washers off the old wheel but discard any plain M8 washers.

Insert the skewer bolt through the front axle bush then the RH tab-washer (tab facing fork) and into the axle from the right hand side. **Note:** Some P-types have a special RH tab-washer that will need to be refitted in place of the standard RH tab-washer to protect the control cables when folded.

On the left hand side add the LH tab-washer with the hook wire-form nested inside it. With the knurled detail outermost, screw on the axle nut to retain the wire-form and tighten by hand. Ensure the axle is seated properly (as far as it will go into the drop out slots) and tighten bolt with a 4mm hex drive to 8N m maximum while keeping the wheel central between the forks.

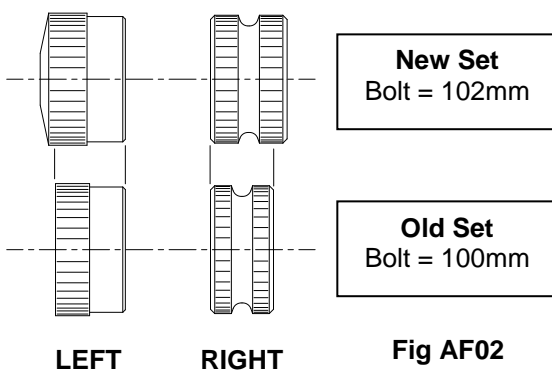

**Important:** the skewer bolt set incorporating the bush and nut has been revised on bikes from 2010 onwards. The bolt is slightly longer and the bush and nut slightly larger (fig AF02). The new 'larger' sets can be used on any hollow axle hubs from Brompton regardless of age but the older 'smaller' sets **must not** be used with the Shimano F703 hub dynamo.

**Be sure to replace with the new set provided and discard the old set. If the wrong set is used the front wheel may not be secured safely!**

**Wheel building**

If building your own Brompton wheel, parts are available individually as shown below.

Dynamo Hub	Spokes as standard	Lacing	Nipples
Shimano F703 Hub only Part: QFWHUBDYN-SHMNO	Plain gauge 14swg Length = 135mm Part: QSPOKFSS-SHMNO	One cross	Steel
SON XS Hub only Part: QFWHUBDYN-SON	Double butted 14swg Length = 137mm Part: QSPOKFSS-SON	One cross	Aluminium

## 2. Fitting the front lamp bracket

New 2010 switched halogen and LED front lamps will not fit on the pressed steel front lamp bracket supplied prior to this date. A new two part design consisting of a wire-form and special concave washer must be used (fig EL313).

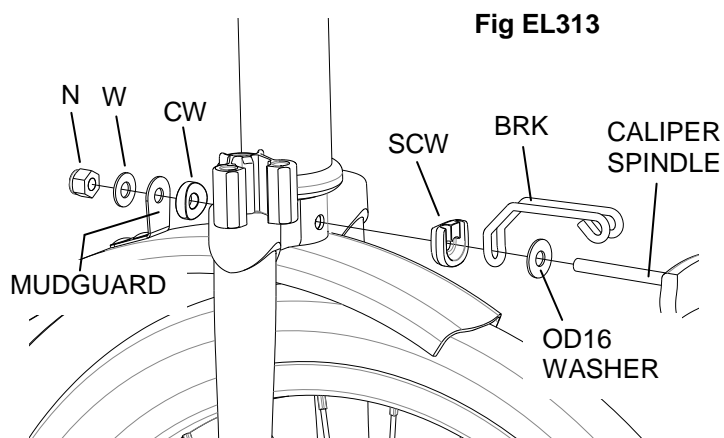

To add or replace the lamp bracket you first need to remove any existing lamps, brackets or reflectors by undoing the brake spindle nut (N) on the back of the fork tube to release the brake calliper unit. Remove all parts and fit the new bracket parts as shown (fig EL313).

The concave washer (SCW) sits against the front of the fork tube with the wire form bracket (BRK) nested inside it. The OD16 washer (two for Titanium) must lie between the calliper and wire-form bracket to hold it in

Feed the parts onto the calliper spindle (washer, bracket then special concave washer) and pass spindle back through the fork tube. Hold the calliper, pressing it into the fork, to hold the bracket parts in place and refit the parts at the rear of the fork to secure the calliper. Typically: plain concave washer (CW), mudguard (if applicable), plain washer (W) and nyloc spindle nut (N).

Tighten the spindle nut ensuring all parts are correctly aligned and the wire-form is seated properly.

**Note:** Bikes with Titanium forks or any bike without mudguards may have more washers (W) to prevent the calliper spindle protruding too far out of the nut (N). As above, two OD16 washers must be used in front and at least one washer (W) under the nut regardless. The spindle should ideally protrude 1-2mm from the nut when tight, never any less.

### For E Version bikes (without mudguards).

The E version requires a guide bracket (GB) to be fitted to the brake spindle to hold the loom off the tyre (fig EL341). It is not possible to move the loom through the guide bracket so the wiring loom earth eyelet connector must first be aligned with the fixing holes in the lamp bracket and the loom passed through the guide bracket before securing the nut on the brake spindle. For rear loom fitting see section 4.

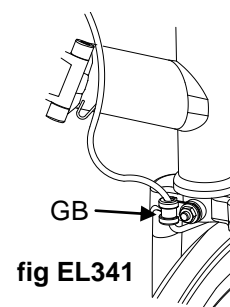

## 3. Fitting the front lamp

**Read first:** If fitting the whole hub dynamo kit the next stage is to fit and connect the front lamp. Check that the connectors on the lamp fit your intended hub before starting.

New for 2010: B+M lumotec switched halogen and LED lamps do not fit in the pressed steel bracket you may already have. These lamps only fit in the new wire-form bracket described above in section 2. Basta ellipsoid switched halogen lamps can be mounted to either bracket but will have connectors to fit the SON XS hub. If changing to a Shimano hub these connectors can be snipped off and the Shimano connector block added as shown in section 3c.

If a rear loom that came with a Basta lamp is already fitted it can be pulled forward slightly to meet the same Basta lamp mounted on a wire-form bracket. If a B+M Lumotec lamp is being fitted (and therefore a wire-form bracket) you can only use the Basta compatible rear loom if you connect the connector (previously earth with black wire) to the live tab on the lamp. This should be bent by hand to 90 degrees to conserve space. Use the brown wire (previously live) as the earth, preferably by connecting your own eyelet. There is no need to swap polarity at the rear lamp.

If fitting an entire hub dynamo kit (or a replacement loom for B+M lumotec switched lamps) you must fit the dedicated rear loom for your chosen front lamp as shown in section 4.

For fitting halogen front lamps see section 3a, for LED front lamps see section 3b. Wire-form front lamp brackets are available from Brompton Bicycle Ltd quoting product code QVBKTFLAMDYN.

### 3a. Fitting the front lamp (Halogen type)

When fitting to a wire-form bracket you need to route both looms correctly from the outset, ready to be secured later in sections 3c and 4. First manipulate the looms so that the rear loom lies to the left and the front loom lies to the right, both passing upwards between the two arms of the bracket (BRK) and over their respective sides as shown (fig EL312).

Holding the lamp locally, push-on the 90 degree live connector firmly onto the tab so that it naturally trails rearwards. Gently separate the bracket arms and manoeuvre the lamp into position between them. At the same time, ensure that the earth eyelet is sandwiched between the lamp body and the inside of the left hand bracket arm. The eyelet sits better when the offset crimped portion is facing inwards (fig EL318). Pass bolt (S) through washer (W) and through the bracket and lamp from the right hand side.

On the left hand side, add the second washer (W) so it lies on the outside of the bracket arm and add the nut (N). Hand-tighten only at this stage.

If a Basta lamp and pressed steel bracket are being used. The earth eyelet must go inside the bracket, but on the right hand side, so as to contact the metal side of the lamp body. The 90 degree live connector can push straight-on, omitting the small plastic plug. The bracket flanges may need to be bent open slightly to fit the eyelet in.

### 3b. Fitting the front lamp (LED type)

The Lumotec IQ Cyo LED lamp has a stand-light and light sensing function.

With the switch set to 'I' the lamp will shine during motion and store charge to power the lamp when stationary for several minutes. The brightness is reduced to conserve power and automatically returns when moving again. The stand light can be switched on ('I') and off ('0') where the stored charge will remain for several days.

Setting the switch to 'S' will automatically cause the front and rear lamp to switch on in twilight or darkness. The light sensor has an 8 second turn-off delay so will not be effected by car headlights etc.

The rear loom was hard wired to the lamp body until July 2011 (MK1) so no connections had to be made. After this date a separate rear loom must be connected by pushing two male tab connectors firmly into their female counterparts on the loom (MK2). It does not matter which tab connects to which connector.

**Note:** It is possible to convert a MK1 lamp to accept the detachable MK2 rear loom by cutting off the old loom and fitting two male connectors yourself. These are available from Brompton quoting TAB-DYNFLAMLED

Once connected, route the looms as shown in fig EL319 (similar to section 3a above). Ensure the rear loom sits on top of the mudguard as it passes under the crown.

Position the lamp between the arms of the bracket then, with a washer (W) pass bolt (S) through from the right. Add another washer and hand-tighten the nut (N).

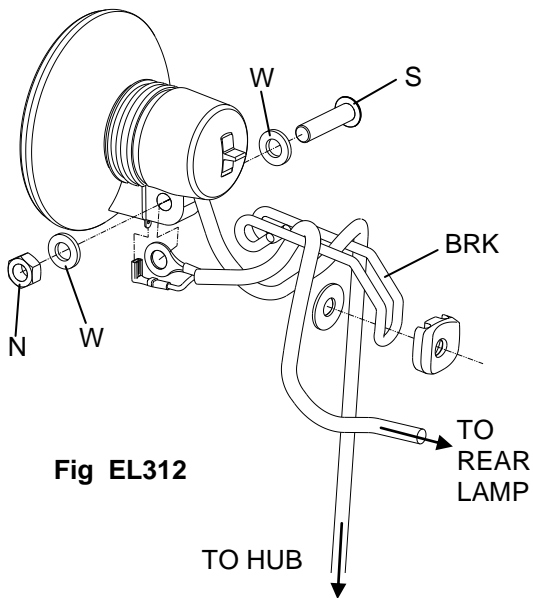

Fig EL312

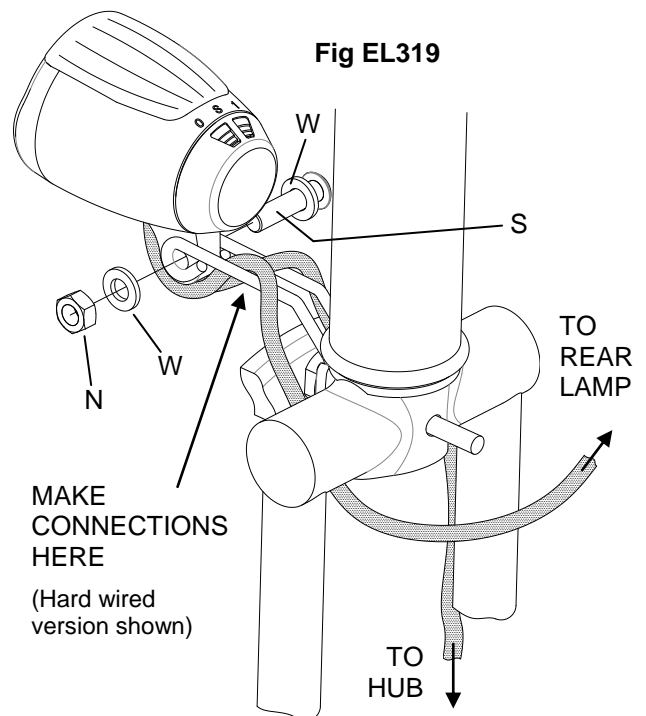
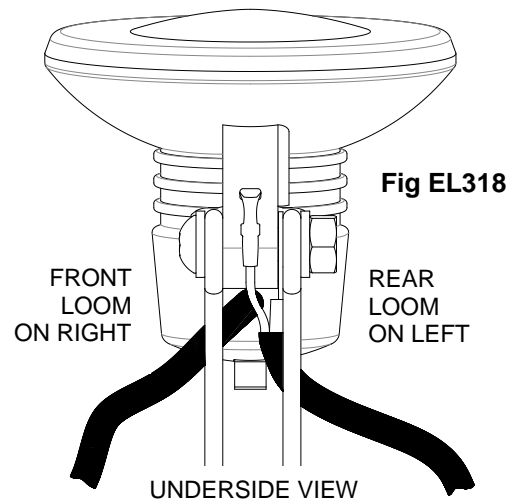
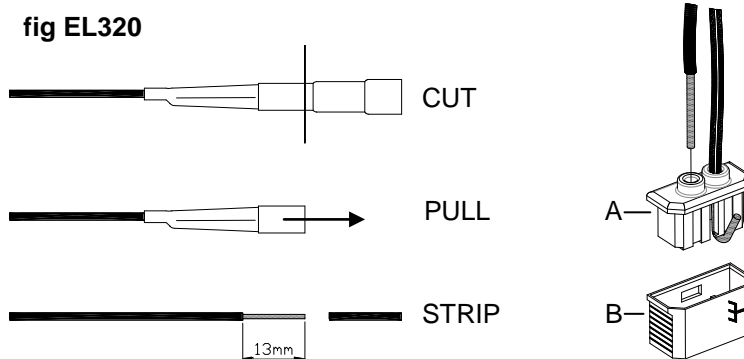

Fig EL319

### **3c. Connecting the front lamp to the hub (Halogen and LED type)**

The following procedure is to electrically connect the front lamp to the hub and secure the front loom. Fixing of the front loom is the same for all types of lamp but there is a different connection method depending on your hub.

Typically Basta halogens and the Lumotec IQ Cyo LED lamp will have connectors for the SON XS hub dynamo, where the Lumotec halogen lamp will have a connector plug for the Shimano F703 hub dynamo already fitted. It is possible to convert SON XS connectors to accept a Shimano connector. Cut where shown (fig EL320) to leave as much wire as possible, pull off the remaining heat shrink and strip 13mm of insulation of the end.



#### **To fit the Shimano connector plug**

First separate the grey part (A) from the black part (B) by depressing the small tab in the hole at the back. Observing the correct polarity is unnecessary so Insert each wire until the insulation just passes the inner hole and bend the bare strands sharply upwards, keeping them neat and confined to the grooves in part A. Ensure the two bare ends do not touch each other and press part A into part B.

#### **Securing the front lamp**

As a guide, the lens of most lamps should be perpendicular to the axis of the front frame tube as shown. Once positioned, tighten the lamp mounting bolt fully and check there is ample clearance to avoid the mudguard and/or any luggage option. The bracket can be tweaked into the correct position using gentle bending and twisting.

#### **Securing the front loom**

The front loom passes over the right hand bracket arm and down the right hand fork blade (fig EL321). First slide the outer sleeve right up to the lamp body and loosely position the longest tie wrap at the top (TW). Manipulate the loom above TW so that it just clears the calliper and secure TW tightly. Connect the plug to the hub by pressing it on firmly until it clicks in place. The plug will only fit one way round. Place the middle tie wrap just above the mudguard-stay-tab and the lower tie wrap to leave an adequate loop (L) to allow for easy disconnection when removing the wheel.

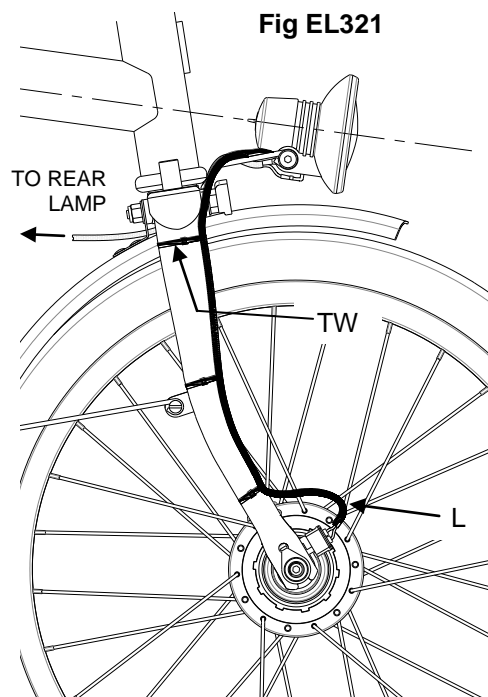

If you have a SON XS dynamo hub simply push on the connectors as far as they will go. The connectors can go either way round and can fit to either tab. When removing SON connectors hold them as low down as possible to avoid stressing the wires. Gently work them side to side without using a jerking action or bending the connectors.

Switch on the lamp and check that it works by spinning the wheel a little. If the lamp does not shine or flicker, re-check all connections.

If necessary bend the bracket down a little so that it does not foul on the headset bearing cup.

Loop L should be sculpted into the neatest arrangement regardless of connector type.

## 4. Routing the Rear Wiring Loom (Halogen and LED type)

**Read First:** The route the rear loom takes is identical for all front lamp types, as is the fixing method. First electrically connect the rear loom to your chosen front lamp as described in Section 3a. for Halogen lamps or section 3b. for LED lamps.

You will need to remove any existing rear lamp or reflector from its bracket, while leaving the brackets in place. Removal is the opposite of refitting as shown in section 5.

First route the loom from front to back. Then, secure the loom with tie wraps working from back to front by carefully following the guidelines below. The details at the rear frame are different, depending if you have a rear rack fitted (R Version) or not (L Version).

### Routing the rear wiring loom (Bicycle)

First ensure the outer sleeve of the loom is pushed up as close as possible to the lamp body and that the two wires are protruding out of the free end as much as possible. Double these wires back to retain the sleeve and make it easier to feed the loom along. Do not pull the cut insulation off yet.

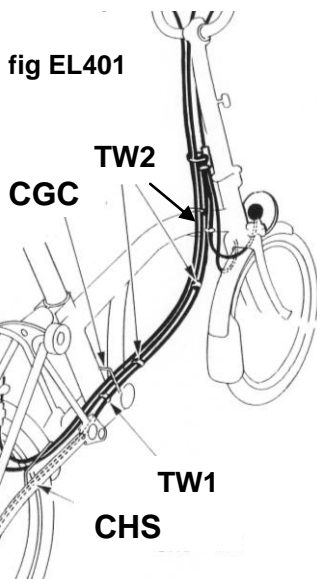

Pass through the gap between the underside of the fork crown and the mudguard on the left hand side of the bike (fig EL319 and EL321 Section 3). Pull all the available loom completely through. For E Versions see note alongside fig EL341 section 2.

From above, pass through the ring on the cable gatherer tube (CGT) until the loom lies loosely alongside the front brake cable (fig EL49). Do not pass through the wire loop (CGF). Do not make a sharp fold in the loom at the top until later.

Pass the loom rearwards through the centre cable guide (CGC) and straight into the right hand chain stay tube (fig EL401). As soon as it emerges at the rear, exit through the large hole (J) (fig EL45) in the rear axle plate from the inside out. Skip to the relevant paragraph below depending if you have an R version or an L version.

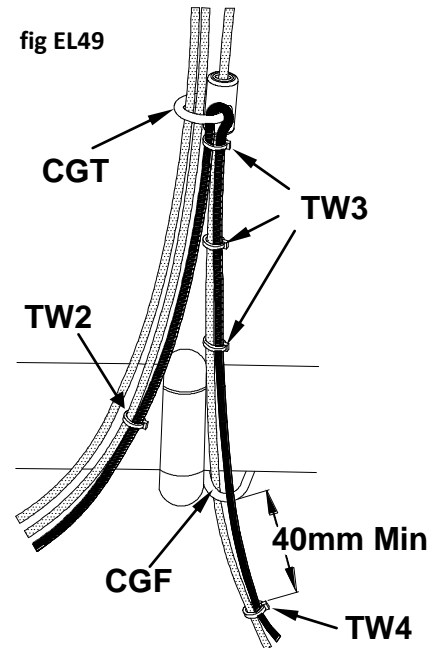

### Routing the rear loom (R version with rear rack fitted)

From the axle-plate-hole, pass forwards between the rack stays and wrap one and a half times around the inside stay in an upwards direction. The free end should now lead straight to the rear lamp from the inside of the inside stay (fig EL46). Pull ample loom through to make connecting the rear lamp easy and connect the lamp as shown in section 5.

Finally, remove all slack by gently working the loom to the front of the rear frame. Skip to section 4a to secure the loom to the bike.

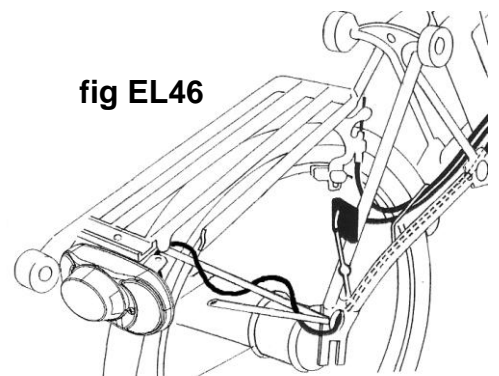

### Routing the rear loom (L or E version without rack)

From the axle-plate-hole, follow the right hand seat stay tube (SSR) upwards. Pull ample loom through to make connecting the rear lamp easy and connect the lamp as shown in section 5.

The rear wiring loom should exit the lamp to the right and pass in front of the brake cross-tube before running along the inboard side of the frame tube SSR (fig EL45). Remove all slack by gently working the loom to the front and add the three tie wraps (TW) from the top down; one above the brake cross-tube, one under the cable pulley and one just up from the bottom as shown. Progress to section 4a to secure the remaining loom to the bike.

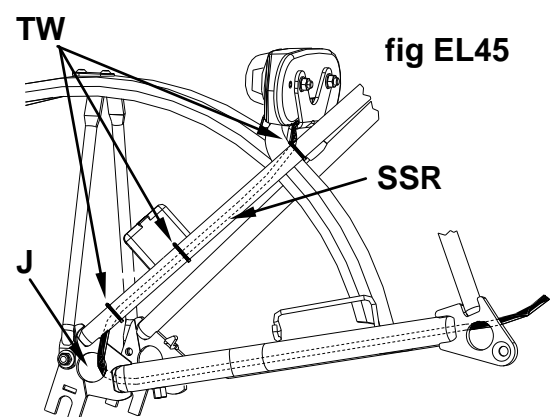

## 4a. Securing the Rear Wiring Loom (All Types)

Satisfied that the loom is correctly secured at the rear frame as described in section 4, continue adding the tie wraps from the back to the front of the bicycle pulling the loom forwards as you go to eliminate slack. Correct positioning of the tie wraps is important to avoid adversely influencing the control cables, in particular the front brake cable.

The loom should follow the main cable run in a smooth arc and attach to the lowest possible control cable, as dictated at the rear frame.

Before fitting tie wraps, pull the loom gently forward from in front of the chain wheel until all the slack at the rear frame is removed without it being excessively taut.

With the bike unfolded first fit TW1 (fig EL401) just behind the centre cable guide (CGC) through a gap in the chain wheel. The other three tie wraps (TW2) should be equally spaced between TW1 and the cable gatherer (CGT) where shown (fig EL401 and fig EL49).

With these four tie wraps in place fold the loom back on itself over the cable gatherer ring. Tie together only, the two strands of loom just below the ring with one of three tie-wraps (TW3). Place the next just above the hinge with the third in-between the two.

Add the final, most important, tie wrap (TW4) 40mm below the CGF where shown. The remaining loom forward of this point should provide a loop to accommodate full steering lock left and right without undue stress on the loom. Check the front brake cable does not catch anything upon folding.

## 5. Fitting the Rear lamp (All types)

### Rear lamp stand-light function

Upon cycling, charge will build up in the internal capacitor so the rear lamp will remain lit for a number of minutes when the bike is stationary and the dynamo has stopped turning. Full charge will be obtained after a few minutes cycling; anything less and the stand light time will be reduced accordingly.

**First:** If replacing a bottle dynamo, remove the bottle dynamo from its stay and discard the looms.

To replace rear lamps or if switching from battery lamps or reflectors, use the existing brackets and fasteners and leave the brackets connected to the bike. Images below will assist.

Dynamo lamps require the wires to be connected before fixing the lamp to its bracket. With the loom fully routed as described above in section 4, insert the wires into the connector plug. This will need to be prized out of new lamps or retained from existing lamps. Insert each wire into a small hole as far as possible and bend sharply over on the recessed side. Observing polarity is insignificant but ensure the bare wires do not touch each other. Push the plug fully into the lamp body.

Fit using the M5 nuts (N) and washers (W) (fig EL25 for R versions, fig EL21 for L and E versions). For either bracket, do not set the lamp too high as it may get damaged on the floor upon folding. The two bolts should be about half way down their slots. To finish, tighten all nuts and screws and check for a secure fit.

Some older L or E version bikes may not have bracket H (fig EL21) in place. They are available from Brompton Bicycle Ltd quoting product code QVBKTRLAM-NR.

