

## ADVANCE 4 SPEED CASSETTE

### IMPORTANT INFORMATION

- If you are unsure of the correct fitting process please consult your Brompton dealer or Brompton Technical Support [support@brompton.co.uk](mailto:support@brompton.co.uk).

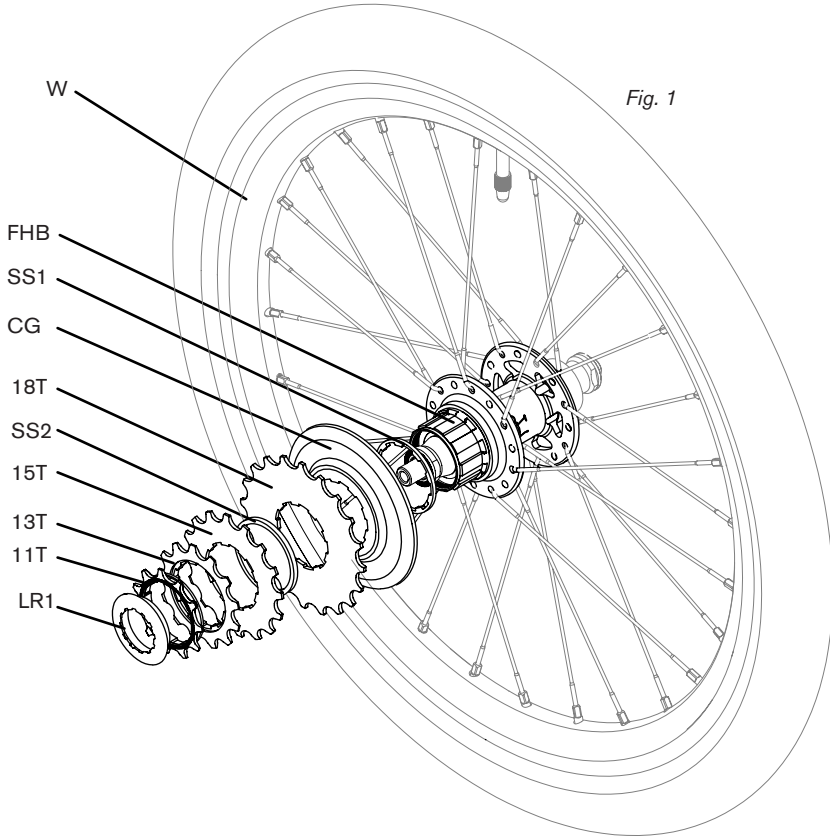

### FITTING THE CASSETTE

To fit the cassette, you will need a cassette tool. Lightly grease the freehub body FHB, then fit each spacer and sprocket in the order shown. (fig. 1) Each component except spacer 2 SS2 has to be aligned to the spline on the FHB to fit. Position the cassette tool in place to engage with the locking ring LR then tighten to 45Nm .

### REMOVING THE CASSETTE

To remove the cassette, you will need a cassette tool and a chain whip. Position the cassette tool in place and then the chain whip. Undo the locking ring.



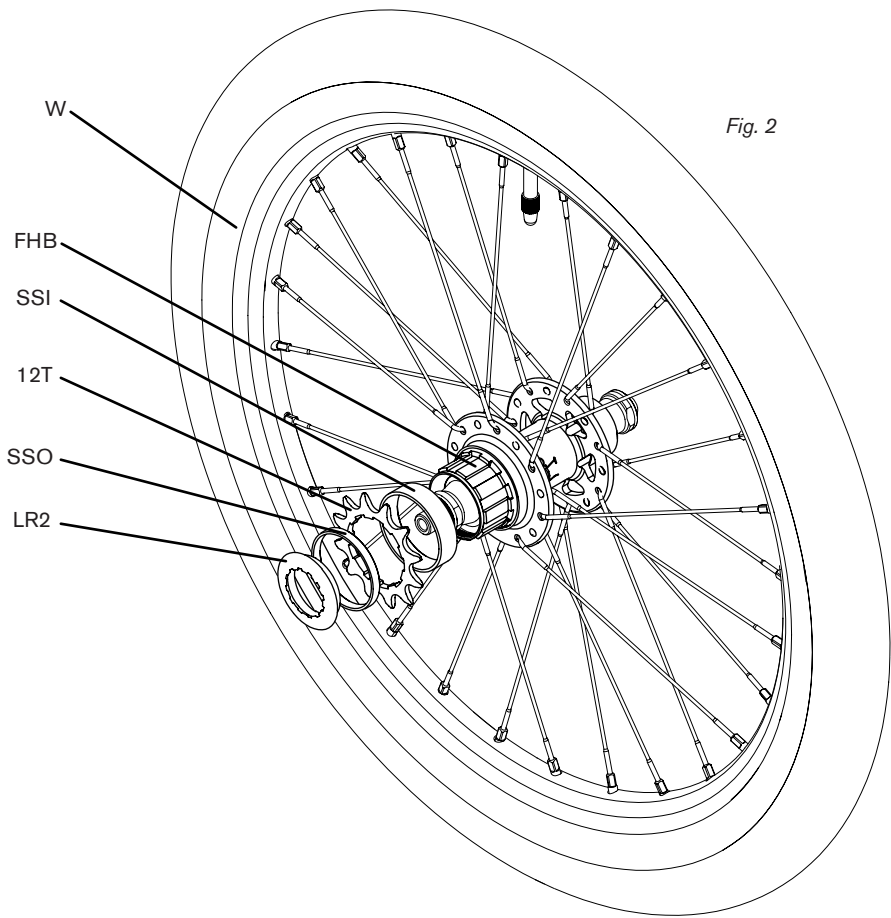

Fig. 2

### **FITTING THE SINGLE SPEED SPROCKET**

To fit the single speed sprocket, you will need a cassette tool. Fit the wider spacer SS1 first followed by the sprocket then the thinner spacer SS2. (fig. 2) The spline of the freehub body FHB has to align with the sprocket to fit. Position the cassette tool in place to engage with the locking LR then tighten to 45Nm .

### **REMOVING THE SINGLE SPEED SPROCKET**

To remove the single sprocket, you will need a cassette tool and a chain whip. Position the cassette tool and then the chain whip. Undo the locking.

