

OPTION 1

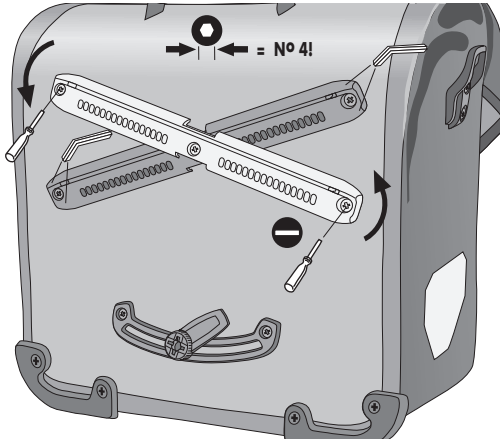

OPTION 2

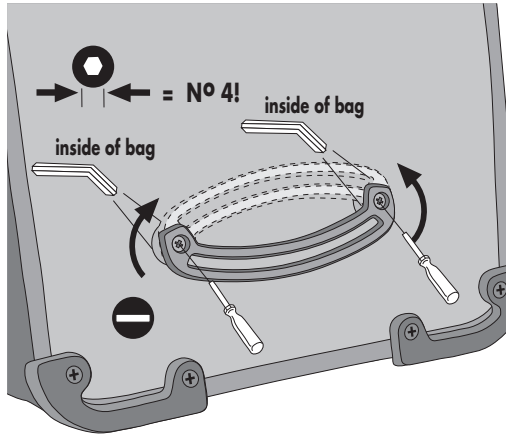

OPTION 3

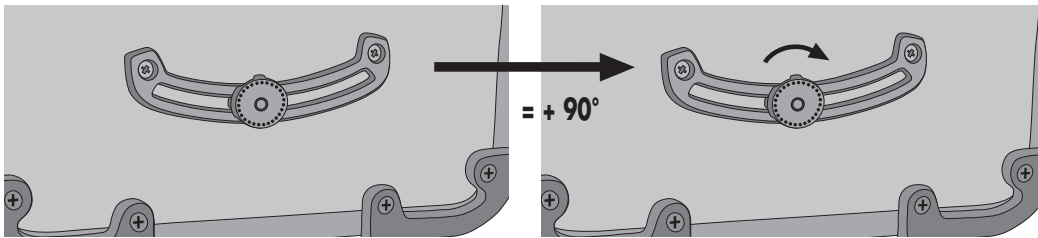
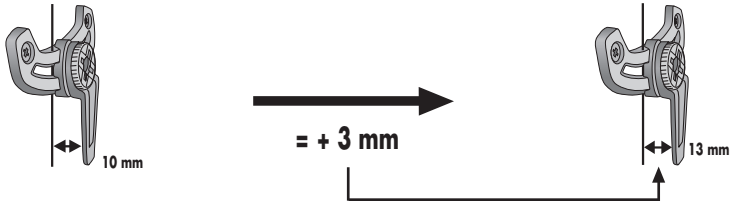

- 1.) 100 km (60 Miles)
- 2.) 500 km (300 Miles)
- 3.) 1000 km (600 Miles)
- 4.) 1500 km (900 Miles)
- etc.

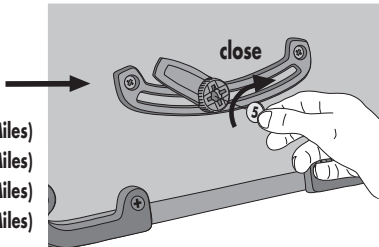

DOWNTOWN2 QL2.1

- DE **MONTAGEANWEISUNG:**
- GB **ASSEMBLY INSTRUCTIONS:**
- FR **INSTRUCTIONS DE MONTAGE:**
- IT **ISTRUZIONI DI MONTAGGIO:**
- NL **MONTAGE HANDLEIDING:**
- DK **MONTERINGSVEJLEDNING:**
- ES **INSTRUCCIONES DE MONTAJE:**
- SE **MONTERINGSANVISNING:**
- NO **MONTERINGSANVISNING:**
- FI **ASENNUSOHJEET:**
- PL **INSTRUKCJA MONTAZU:**
- JP 換気の良い所に保管してください。

ORTLIEB WATERPROOF



QL2.1

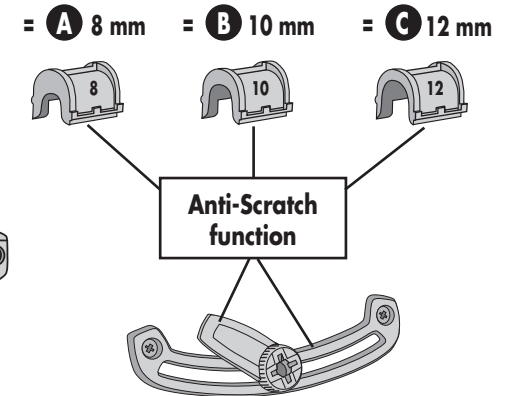
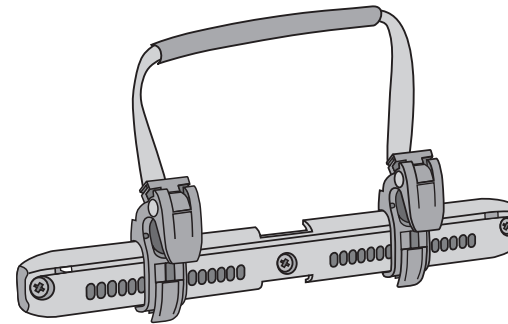

ACCESSOIRES

= + Art. #E193

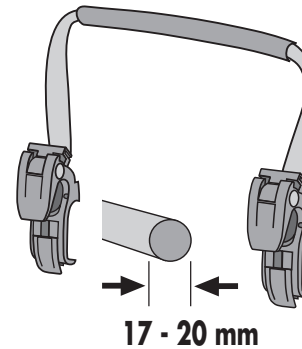

= + Art. #E125 (l)

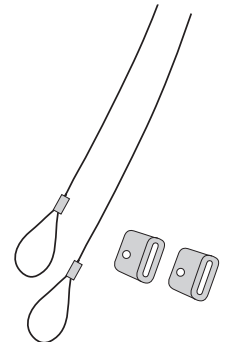

A

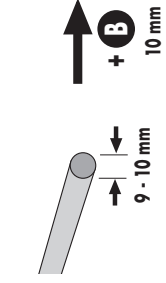
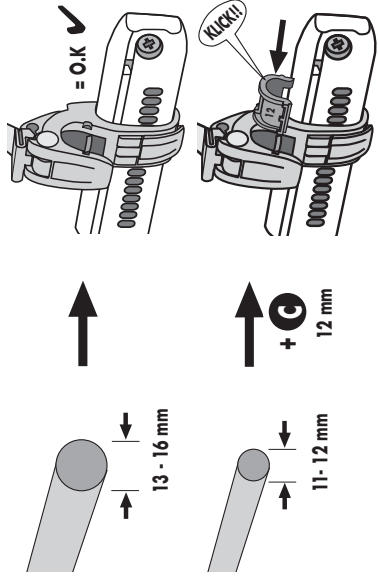

B

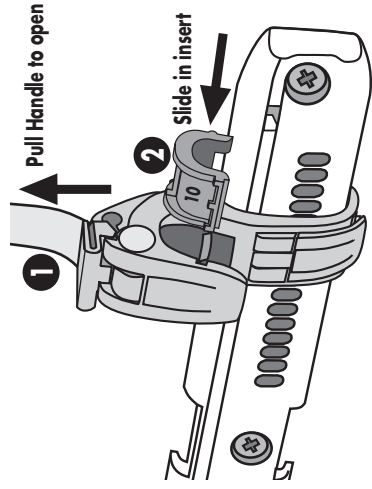

C

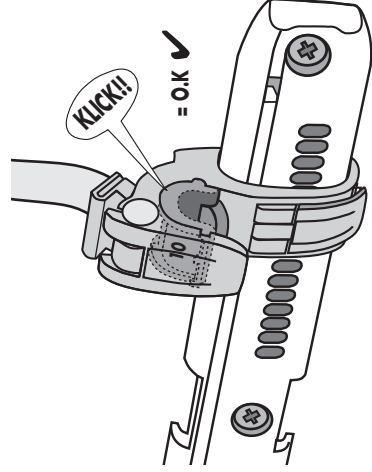

D

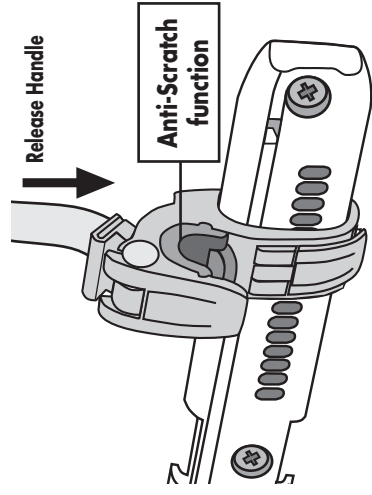

E

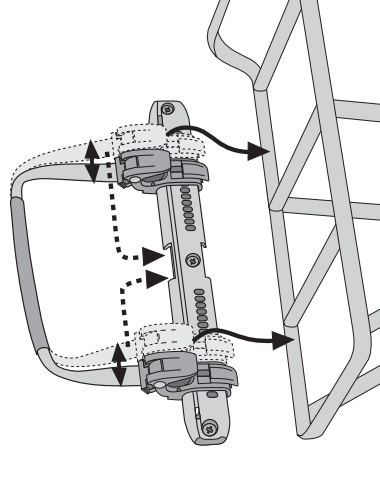

F

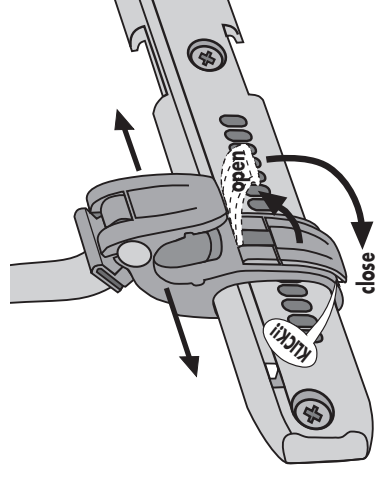

G

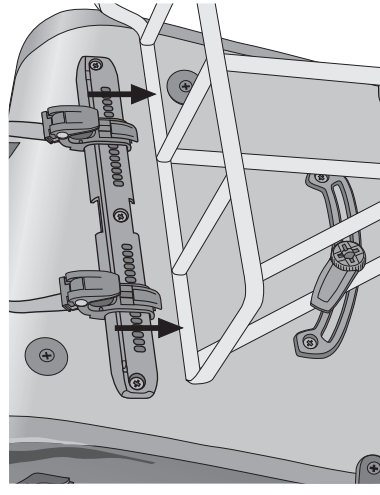

H

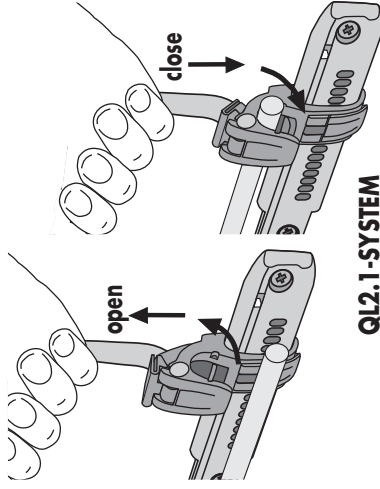

I

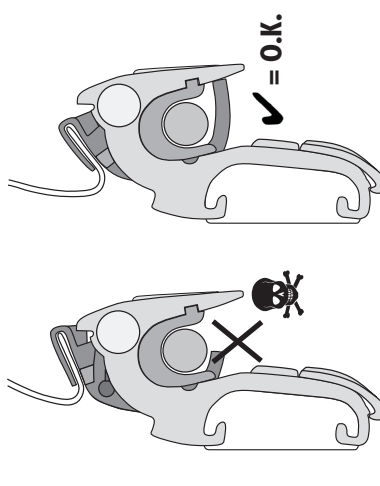

J

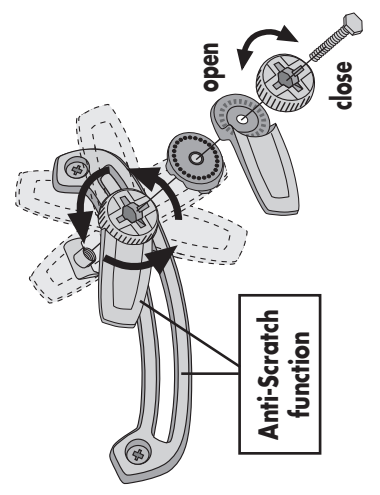

K

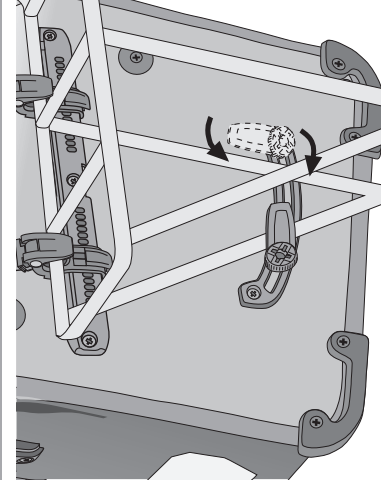

L

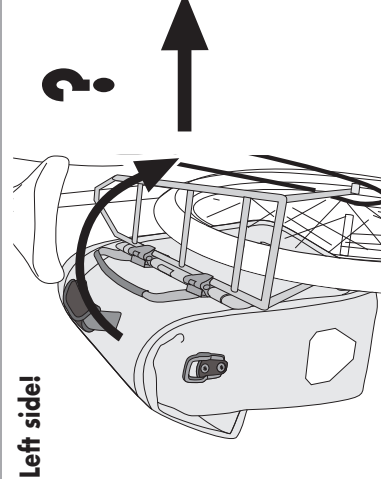

OPTION 1

