

SUPERLIGHT QR PEDALS

IMPORTANT INFORMATION

- Apply anti-seize or regular grease to the QRPM thread, inside the QR pedal mount and to the right hand side pedal thread
- Fit two washers when fitting the QRPM to a carbon crankset while only adding one when fitting to a metal crank
- The QRPM should be torqued to 11.8Nm
- Before riding always check that the detachable pedal is firmly attached by pulling the pedal away from the crank arm
- Make sure the interfacing surfaces of the QR pedal & QRPM are clean, lightly greased and free from debris
- If you are unsure of the correct fitting process please consult your Brompton dealer or Brompton Customer Service support@brompton.co.uk.

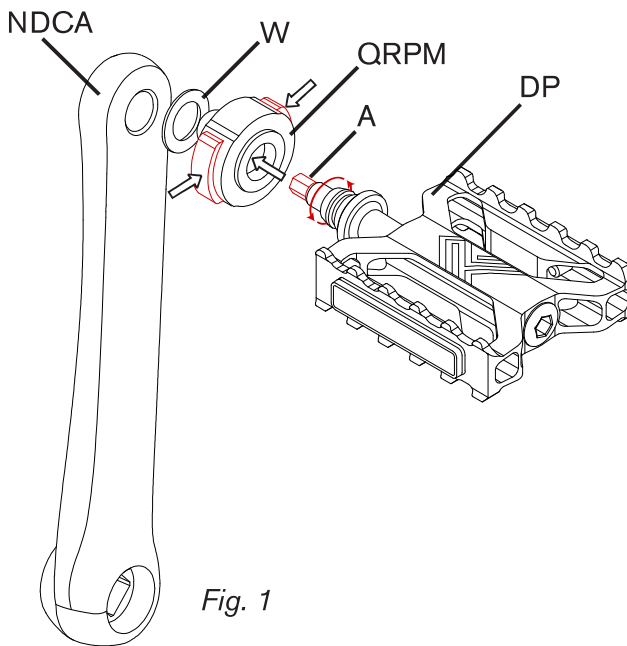

Fig. 1

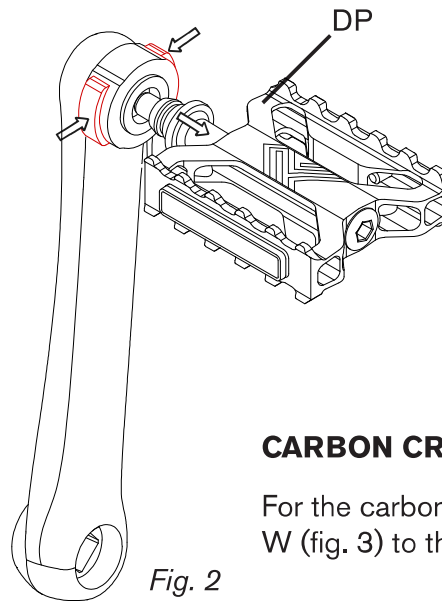

Fig. 2

CARBON CRANKSET

For the carbon crankset, fit two washers W (fig. 3) to the QRPM as shown.

DETACHABLE PEDAL & QR PEDAL MOUNT

To fit the quick release pedal mount QRPM (fig. 1) to the non-drive side crank arm NDCA, place the bike in the parked position by folding the rear frame.

Put the crank arms in a parallel position with the NDCA pointing backwards and away from the rear of the bike, this should give access to the inside of the crank arm.

Fit the washer W (fig. 1) to the QRPM as shown. Fit 1 washer for metal crank and 2 for the carbon crank

Apply anti seize or regular grease to the thread of the QRPM then screw into the outside of the crank arm and tighten to 11.8Nm using a 6mm hex-key. Turn clockwise to install or anti-clockwise to remove.

Apply anti seize or regular grease to the inside of the QRPM once fitted.

To remove the detachable pedal DP when the bike is folded, squeeze both buttons on the QRPM while simultaneously pulling the DP away from the crank arm (fig. 2).

To insert the DP back into the QRPM, push the hex shaped axle A into the QRPM while twisting to line up the hex shaped axle to the inside of the mount (fig. 1). Apply pressure until there is a click to indicate that the DP is fully inserted.

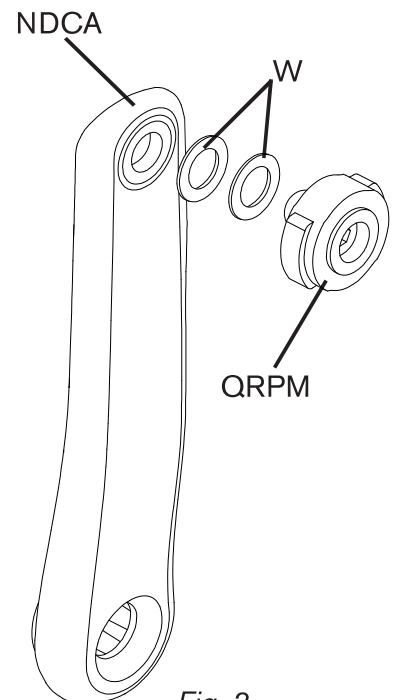

Fig. 3



NON DETACHABLE PEDAL

To fit the non detachable pedal, place the bike in the parked position. The crank arms should be in the parallel position with the crank arm on the drive side pointing backwards.

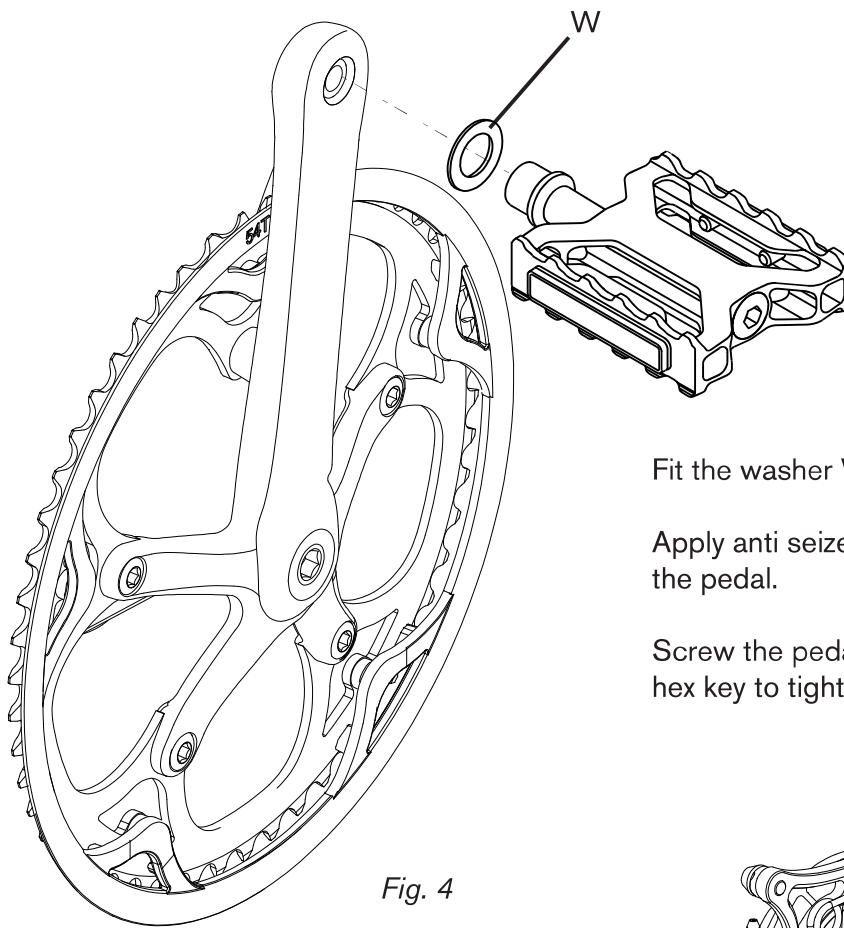

Fig. 4

Fit the washer W to the pedal. (fig. 4)

Apply anti seize grease or regular grease to the thread of the pedal.

Screw the pedal into the crank arm (fig. 4) and use a 8mm hex key to tighten to 20Nm.

FITTING THE PEDAL HOLDER - NON CARBON FORK

To install the quick release pedal holder PH, remove the barrel nut that is holding the brake caliper in place.

Replace with the PH and tighten to 8Nm using a 6mm hex key (fig. 5).

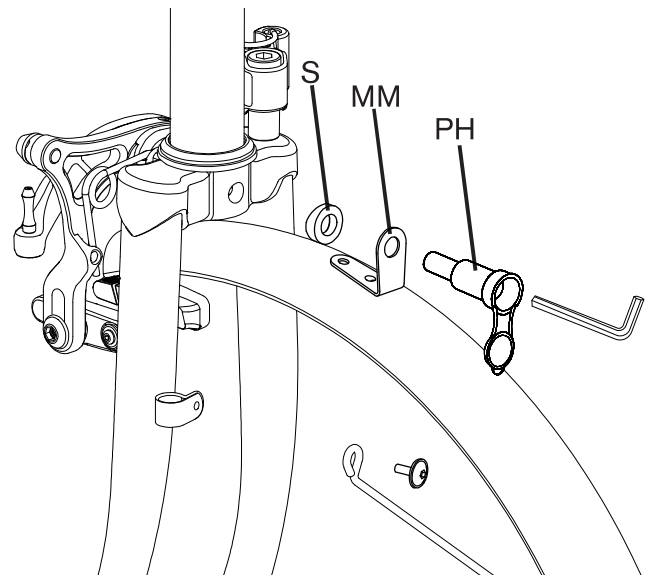
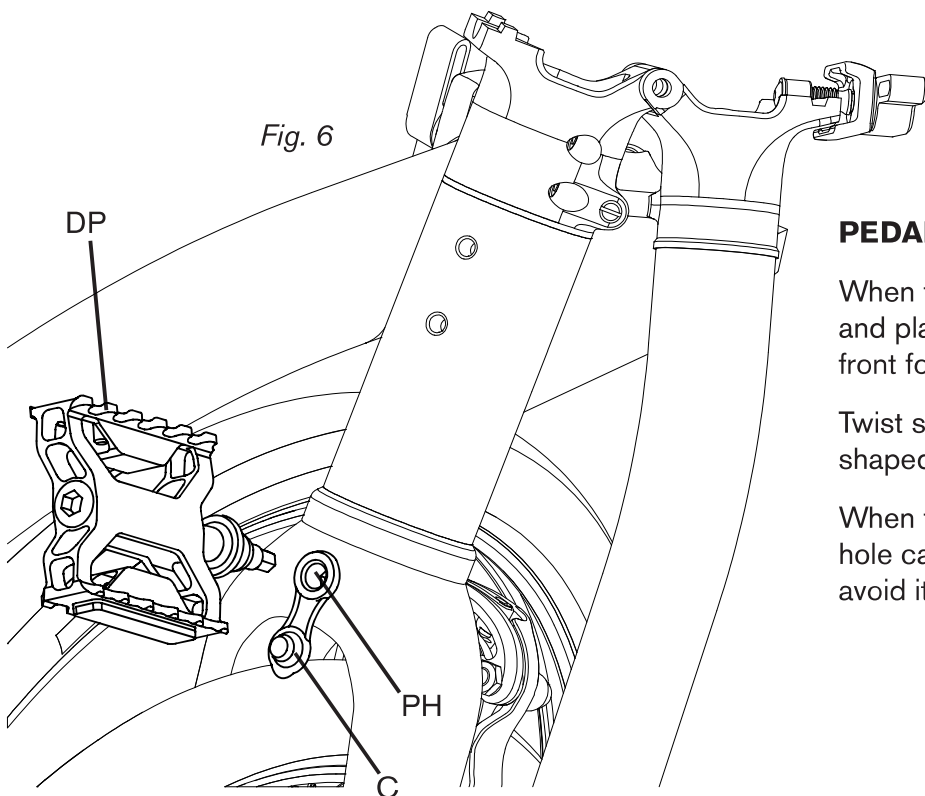

Fig. 5

Fig. 6



PEDAL HOLDER

When the bike is folded, the DP can be removed and placed in the pedal holder PH at the rear of the front fork when carrying or storing the bike (fig. 6).

Twist slowly when inserting to line up the hex shaped axle to the inside of the holder.

When the DP is not being kept in the holder, the hole can be covered with the rubber cover C to avoid it being clogged with debris (fig. 6).

