

2-SPEED GEAR SHIFTER

IMPORTANT INFORMATION

- 2-speed shifters are used on 2 and 6 speed bikes
- These shifters were introduced on 2017 bikes
- This shifter is not compatible with older brake levers or pre 2017 M/H Type bars
- If you are unsure about any fitting or operation instructions please contact a Brompton dealer

USING THE SHIFTER

The 2-speed shifter uses a self-returning lever to change between the two gears. Pushing it down with your thumb will shift into an easier gear and flicking the lever upwards with the back of the thumb will shift into a harder gear (fig.1). It is possible to change gear while pedalling or stationary, though the gear will not engage until the pedals are moving forward. The indicator window (fig. 1, 2) shows you which gear is selected.

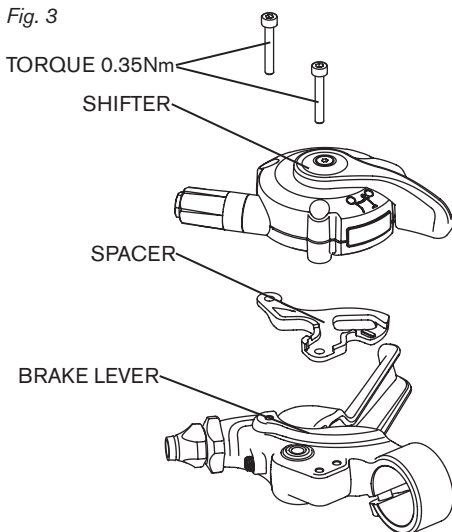
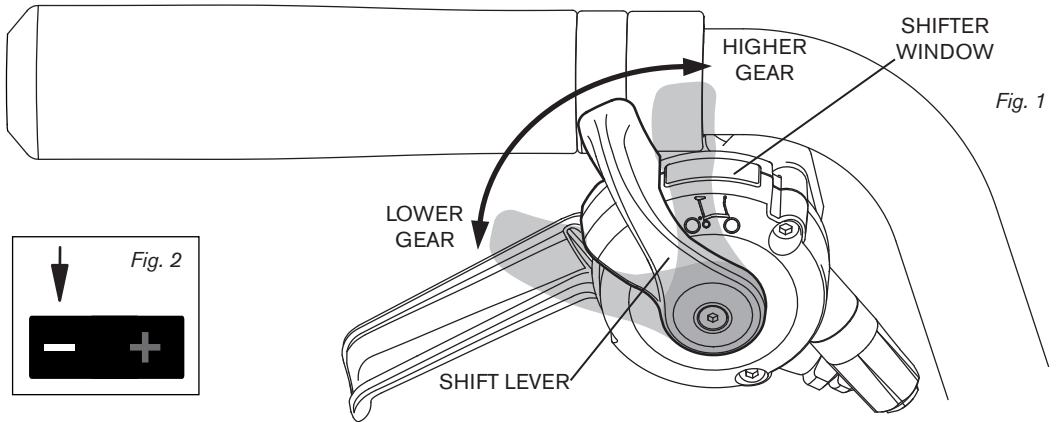

FITTING THE SHIFTER

The shifter mounts to the right hand brake lever, it is held in place by two M3 screws, these should be tightened to **0.35Nm**. Do not overtighten the screws as this can reduce the performance of the shifter and damage the parts.

As standard a spacer (fig. 3) is fitted between the shifter and brake lever. This spacer is vital to ensure clearance between the shift lever and the grip.

On P-Type bikes and also on M, H & S-type bikes using non-standard grips, the locking collar or grip material can interfere with the lever operation, if the spacer is not fitted.



REMOVING THE GEAR CABLE

- Select the highest gear (+)
- Release the cable from the cable connector (fig. 4) by loosening the grub screw
- Select the lowest gear (-) and then press the shift lever downward so it does not obscure the cable entry hole
- Separate the inner cable from the outer housing
- Push the inner cable through the barrel adjuster, until the cable nipple is fed out from the entry hole (fig. 5)
- Pull the cable from the entry hole until it is separated from the shifter

Fig. 4

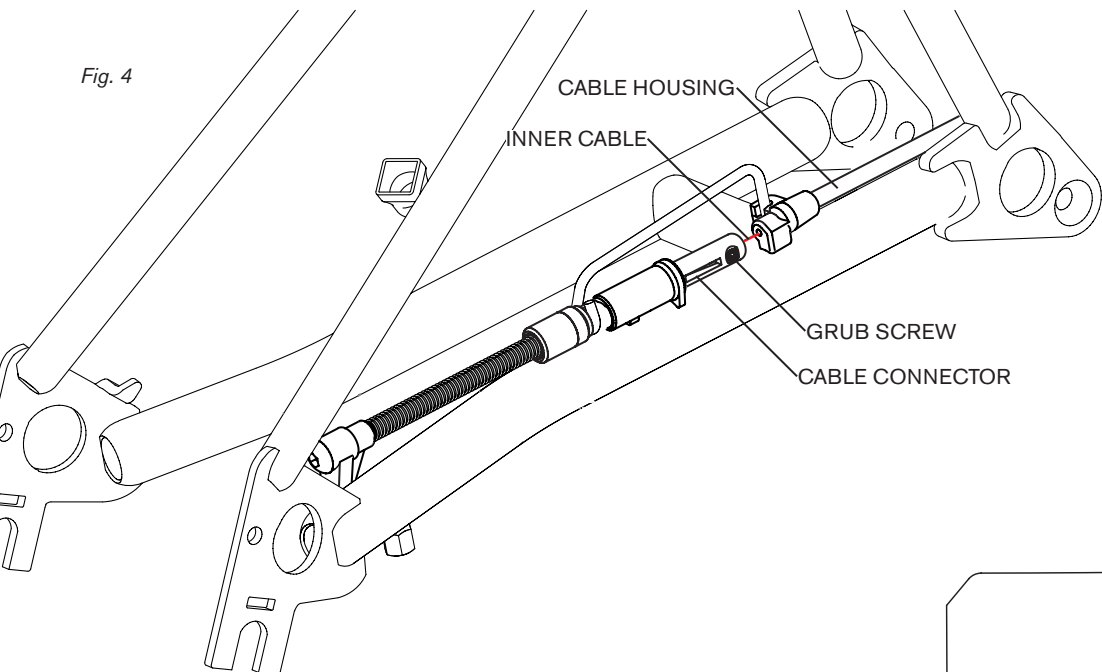

FITTING A NEW CABLE

- Screw the barrel adjuster fully clockwise so that it is at its shortest setting, then unscrew by 2 turns
- Select the lowest gear (-) and then press the shift lever downward so it does not obscure the cable entry hole
- Feed the gear cable into the shifter in a slightly downward direction and through the cable bush
- If there is resistance pushing the cable through the bush pull the cable back a little and try again
- Once you can feel the cable pass through the bush keep feeding it until you feel slight resistance
- Keep feeding it through so that it follows around the guide inside the shifter and exits through the barrel adjuster

DO NOT FORCE THE CABLE AS THIS MAY DAMAGE THE SHIFTER

SETTING THE GEARS

- Insert the gear cable into the housing
- Thread it all the way through so that it exits through the end of the housing
- Using some needle nose pliers or similar pull the cable through the housing and insert fully into the connector
- Tighten the grub screw to secure the cable in the connector
- Use the barrel adjuster on the shifter to make adjustments to the cable tension as needed
- Unscrewing the adjuster will add more tension to the cable and improve shifting into the lower gear
- Screwing the adjuster inwards will reduce tension and improve shifting into the high gear

Fig. 5

