

CHAIN CATCHER

IMPORTANT INFORMATION

- The chain catcher will only work with the 3 standard spec chainring sizes; 44T, 50T, 54T
- A 3mm hex key will be needed to set the space between the chain catcher arm and the chain
- Thoroughly clean and dry the seat tube, ensuring it is free from dirt and grease before fitting the chain catcher
- Ensure the adhesive pad is free of air pockets
- If you are unsure of the correct fitting process, please consult your Brompton dealer or Brompton Technical Support support@brompton.co.uk

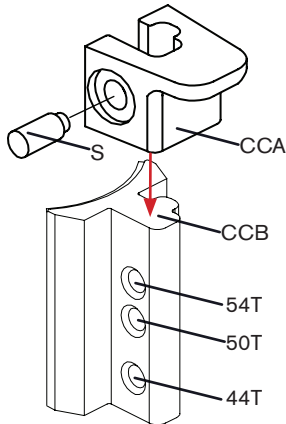

Fig. 1

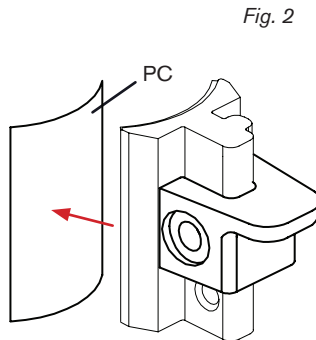

Fig. 2

SCAN HERE



VIDEO INSTRUCTION

ITEMS INCLUDED

- 1x Chain catcher base
- 1x Chain catcher arm
- 1x Screw

STEP 1. FITTING THE CHAIN CATCHER ARM TO THE BASE

Fit the chain catcher arm CCA to the chain catcher base CCB as shown (fig. 1) Align one of 3 holes depending on the chainring fitted, top hole 54T, middle 50T and 44T bottom. Insert screw S and tighten to 0.7Nm.

STEP 2. FITTING THE CHAIN CATCHER TO THE BIKE

Unfold the bike. Put the bike in the first gear, the largest cog on the rear cassette.

Clean and dry seat tube thoroughly to remove any dirt and grease before starting the fitting process.

Place a 3mm hex key in the chain as shown to set the distance between the chain catcher arm and the chain (fig. 3). Remove the protective cover PC from the adhesive pad in preparation for it to be fitted to the bike. (fig. 2)

Fit the assembled chain catcher, ensuring that the CCA is resting directly on top of the hex key and is not overlapping the serial plate. (fig. 4)

Press firmly in place and hold for 5 seconds. Remove the hex key.

Leave undisturbed for 25 minutes before riding.

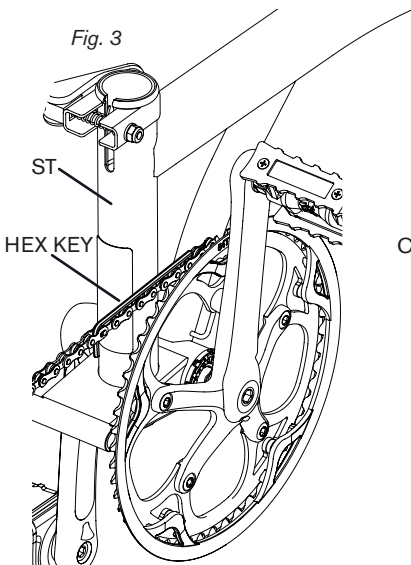

Fig. 3

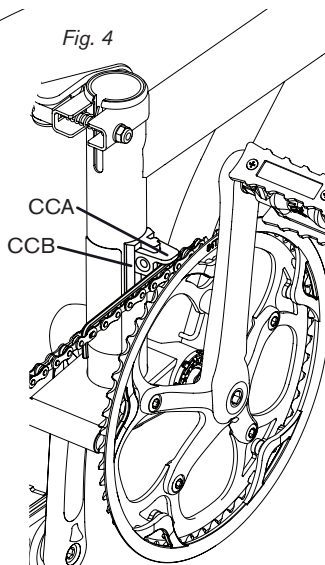

Fig. 4